

HUNTER

Quick Start Guide

SZ09-EN-001

Caution

1. To ensure the printing quality, please don't open the light shield unless it's necessary.
2. Unused photopolymer resin needs to be stored in a dark, dry, and cool place.
3. Please clean the finished model with isopropyl alcohol (IPA).

Warning

Please put on gloves while using photopolymer resin to avoid direct contact with hands.

User Guide

The instruction(user guide) is stored in an attached USB disk.

This guide only applies to Flashforge Hunter DLP 3D printer

1

Kit Contents

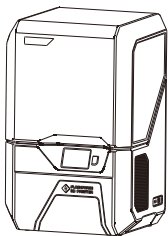

Hunter 3D Printer



Quick Start Guide

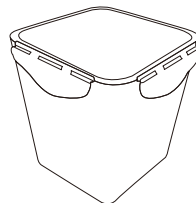

After-sales Service Card

Photopolymer Resin
(500ml)

Rinse Bucket

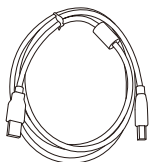

USB Cable



Power Cable

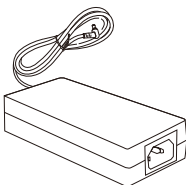

Power Adapter

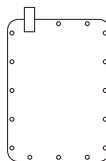

VAT Film



Vinyl Gloves



Soft Cloth

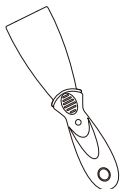

Metal Scraper

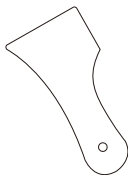

Plastic Scraper

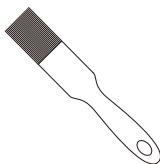

Brush

Wrench
Accessories Kits

Spare Screw Kits

Wrench Accessories Kit Contents:

Hexagon wrench(2.5mm*1/3mm*1/5mm*1,)
Phillips Screwdriver, USB Disk, Plastic Tweezers,

Spare Screw Kits Contents:

Hexagon Screws, Flat Washer,
Spring Washer

2

Getting to Know Your HUNTER

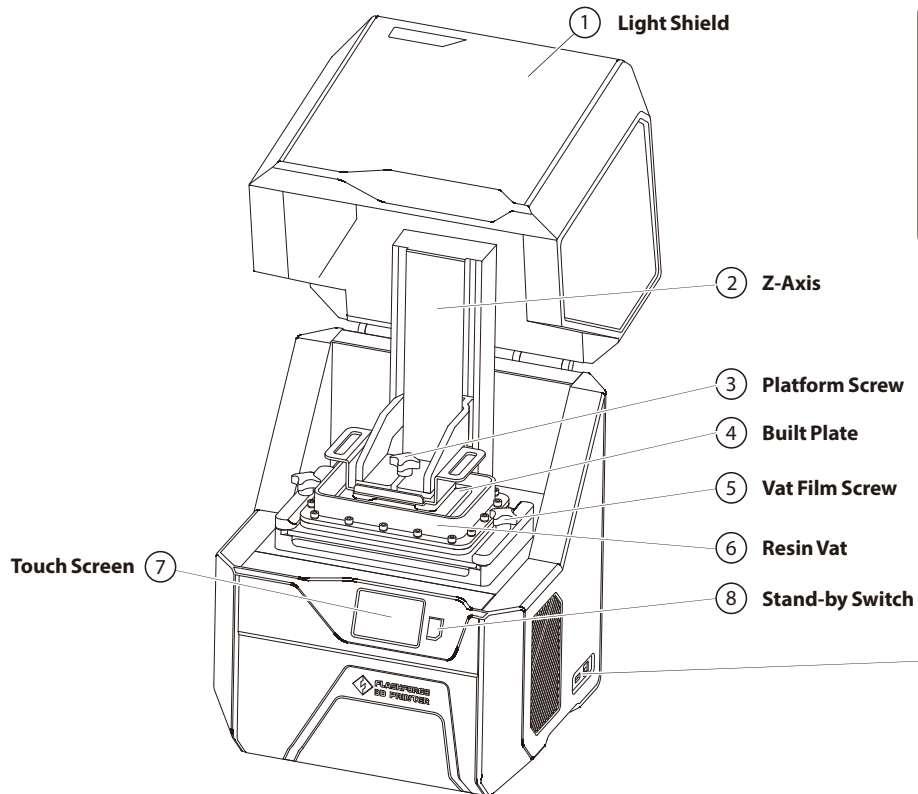

The Back of the Printer

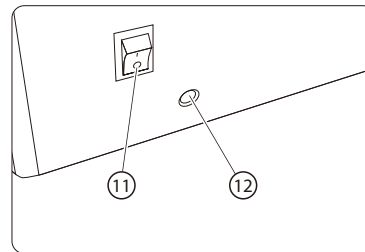

11 Power Switch

12 Power Input Port

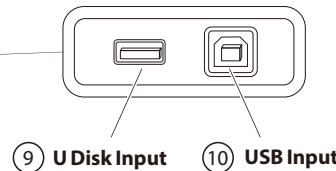

9 U Disk Input

10 USB Input

3

Unpacking



1. Please lay flat the printer on a clean platform, open the box from the bottom.



2. Set the hunter upright, lay the white foam on the floor and lift the carton.



3. Remove the foam and accessory box from top. You will find a Quick Start Guide, an After-sales Service Card and a spare Vat Film inside.



4. Accessory box contains USB cable, power cable, scraper, plastic scraper, brush, soft cloth, spare screw kits, plastic tweezers, hexagon wrench (2.5mm*1/3mm*1/4mm*1), Phillips screwdriver, USB Disk.

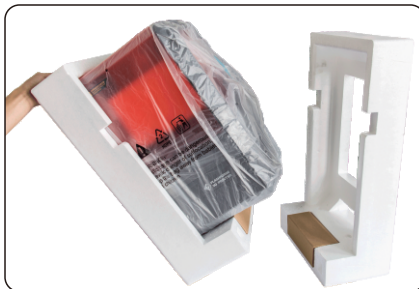

5. Tilt the Hunter to the left and remove the foam on the right. And vice versa remove the foam on the left.



6. There is a carton box in each foam, one holds a 500ml bottle of Photopolymer Resin, another includes a power adapter.



7. Remove the plastic bag (the seal is on the bottom).



8. Remove the clear protection film.



9. Open the light shield.



10. Tear off the protection film as shown.



11. Tear off the protection film on the foam.



12. Hold the circled place with hands, then lift it up until the bottom foam is raised above the resin vat.



13. Take out the foam block.



14. There is a rinse bucket in the foam, which contains a pair of vinyl gloves.

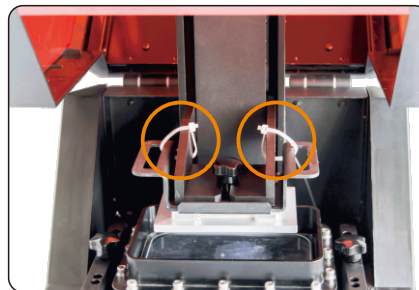

15. Cut the white tie that holds the z-axis.

**Now you have finished unpacking,
you can see the complete Hunter 3D printer and accessories.**

4

Pour Photopolymer Resin into Vat

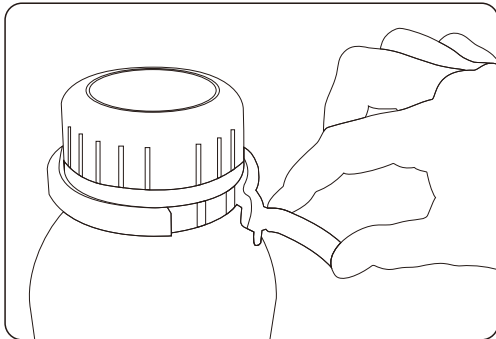

1. Tear off the seal, then open the cap.

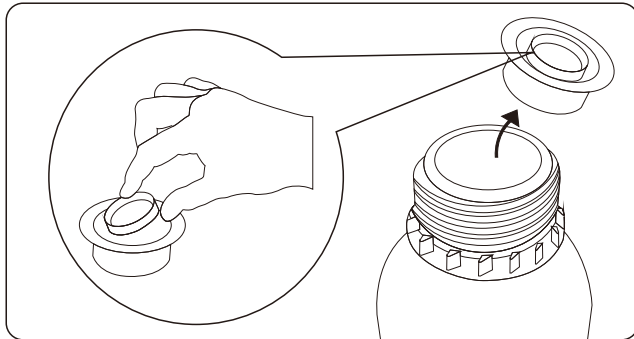

2. There is a rubber plug at the mouth of the bottle. Lift the ring open and take out the rubber plug.

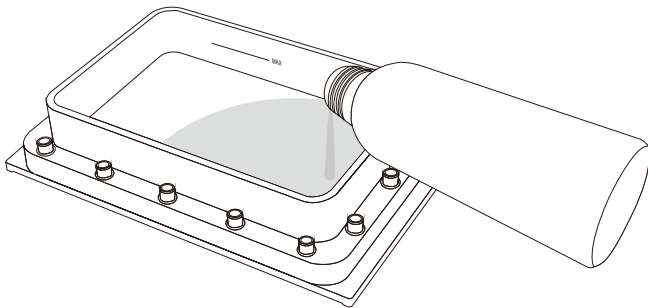

3. Pour the photopolymer resin into resin vat slowly, fill it one-third full each time.
Don't go higher than the maximum scale mark. Be sure not to pour too fast to avoid spilling.

Caution

- Pour photopolymer resin slowly to prevent liquids from spilling out.
- Please put on gloves during operation.

5

First Print

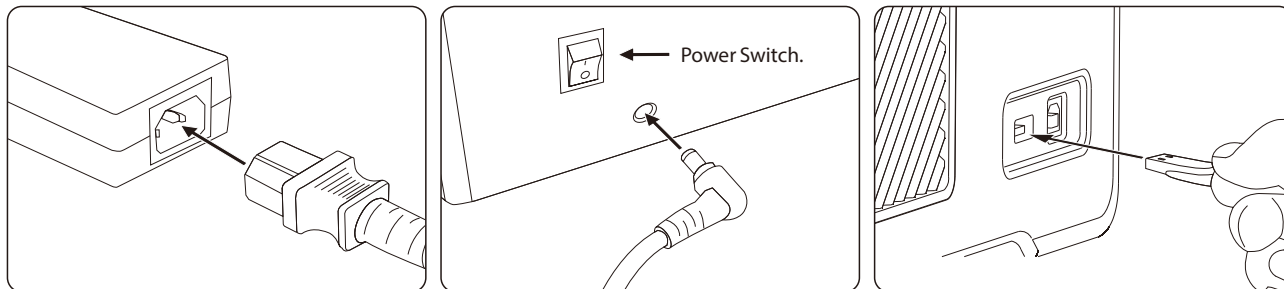

1. Connect power cable and power cord adapter.
2. Plug the power cable into the outlet on the back of Hunter and turn on the power button.
3. Insert the attached USB stick into Hunter.

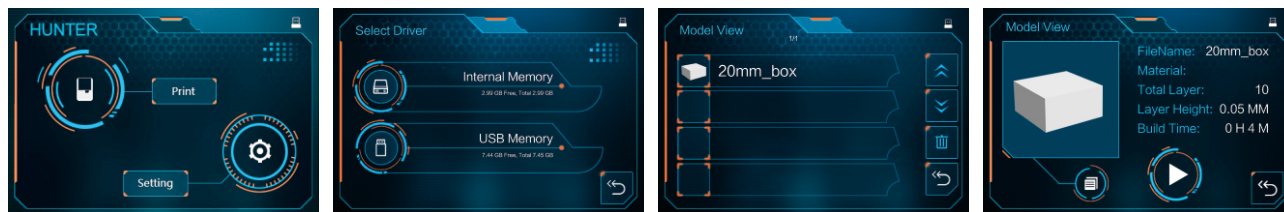

3. Click [Print]-[USB Memory]- [20mm_box], then click start icon to start printing.

6 Remove the Build Plate



1. After finishing printing, please put on vinyl gloves and open the light shield.

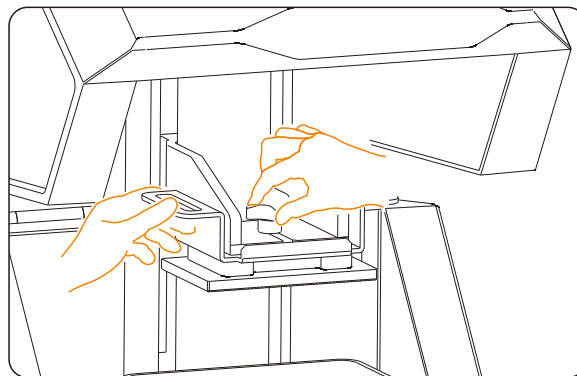
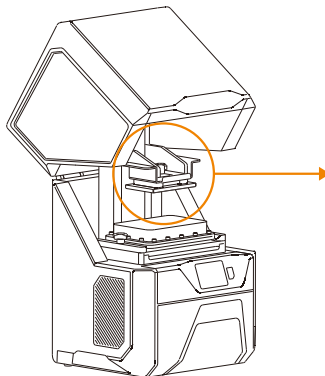

2. Hold the build plate and loosen the bolt until the build plate can move.

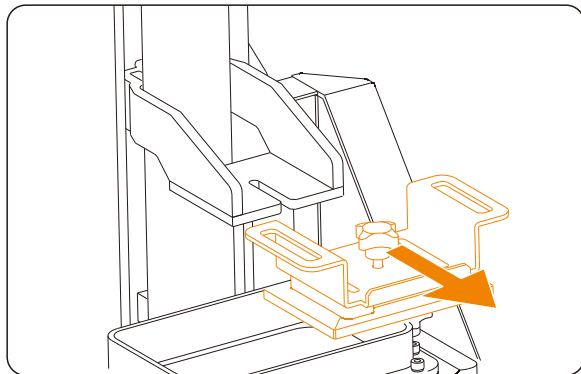

3. Take out the build plate carefully from horizontal direction.

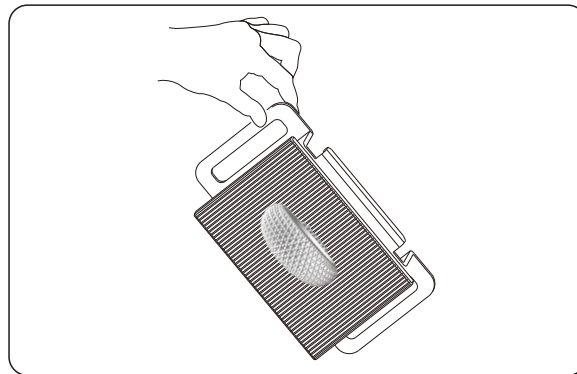

4. Hold the build plate on top of the vat for the residue resin to run out.

7

Clean and Remove the Model

Caution: IPA is highly flammable!

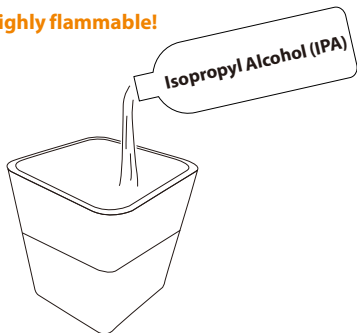

1. Pour the isopropyl alcohol (IPA) into the rinse bucket halfway.

Caution: The metal scraper is very sharp.

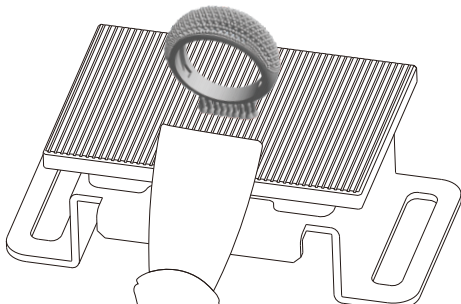

3. Once clean, put the platform on the work table, remove the print with metal scraper.

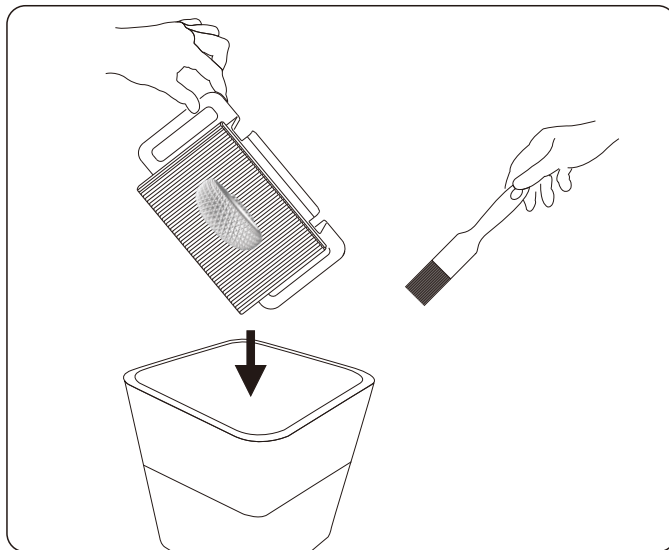

2. Immerse the built plate and the print into isopropyl alcohol (IPA), and rinse it thoroughly.

Note

For some prints that are difficult to remove, use the plastic tweezers to detach the print from the build plate grooves.

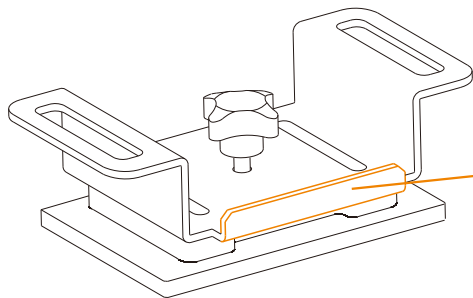

Caution

- Please pay attention to the direction during installation as shown in the left.

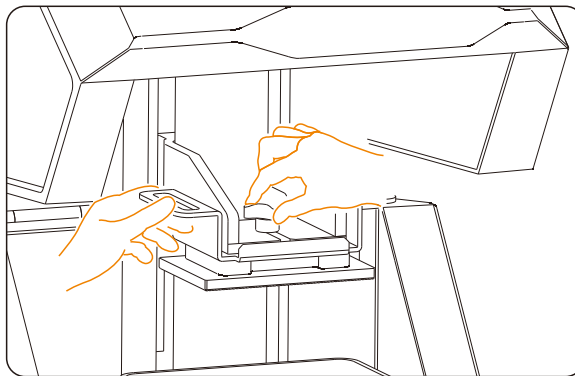
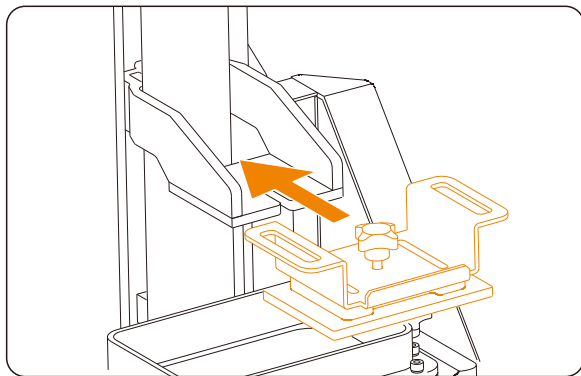

4. Adjust the direction when needed, put the build platform back in place then tighten the bolt.

8 How to Remove the Resin Vat

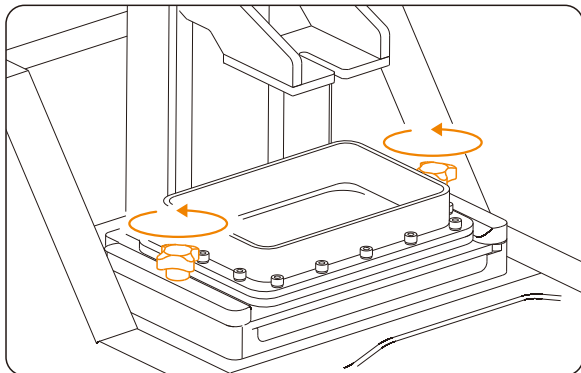

1. Unscrew the two screw on both sides.

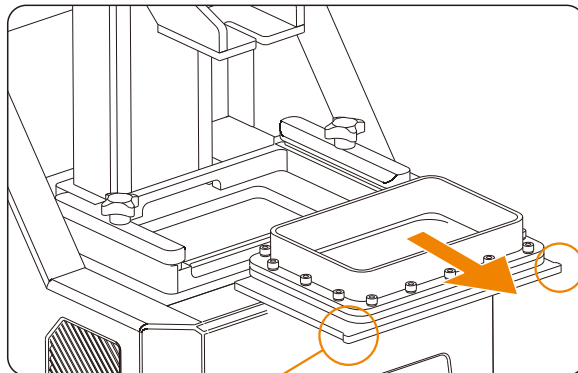

2. Take out the resin vat.

Caution

- Please pay attention to the direction during installation. Refer to figure 2.
- If there is photopolymer resin left in resin vat, please put it back to the printer and cover it with light shield as soon as possible to avoid the liquid being solidified by exposing to light.

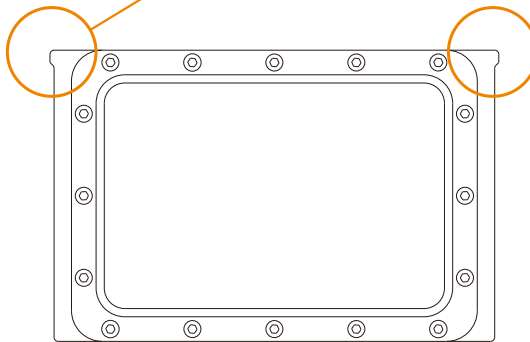

9

How to Change the Vat Film

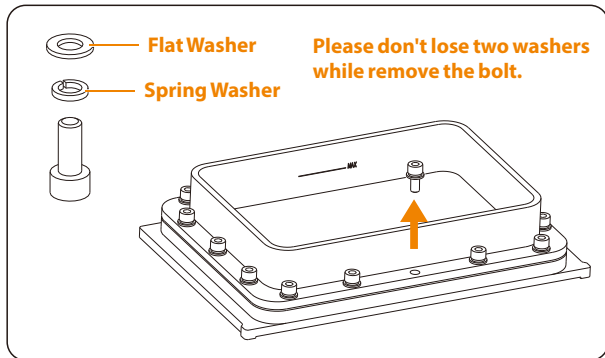

1. Place resin vat flat on workbench, unscrew all bolts with hexagon wrench.

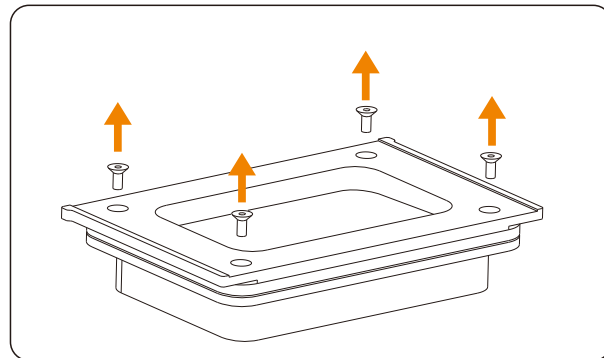

2. Turn the resin vat over, unscrew four bolts from the bottom of the resin vat plate.

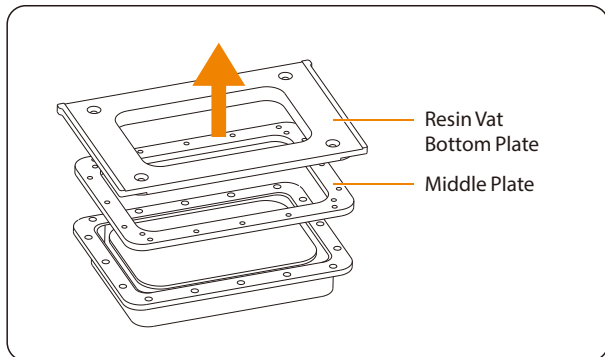

3. Detach the resin vat bottom plate and the middle plate.

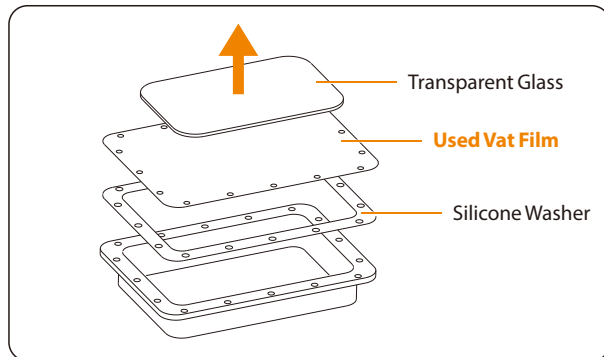

4. Remove the transparent glass, used vat film, silicone washer. Keep the glass and silicone washer, discard the used vat film.

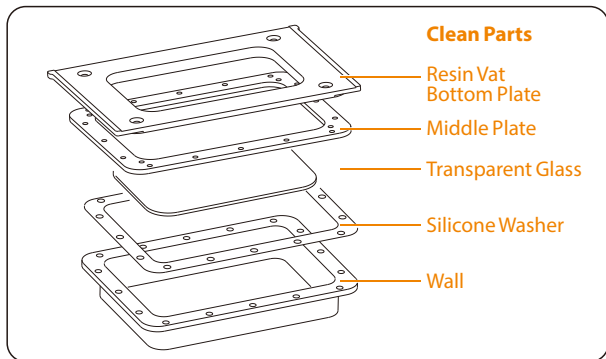

5. Carefully clean the resin vat bottom plate, middle plate, wall, transparent glass and silicone washer. Especially for the transparent glass, please make it dustless without fingerprints.

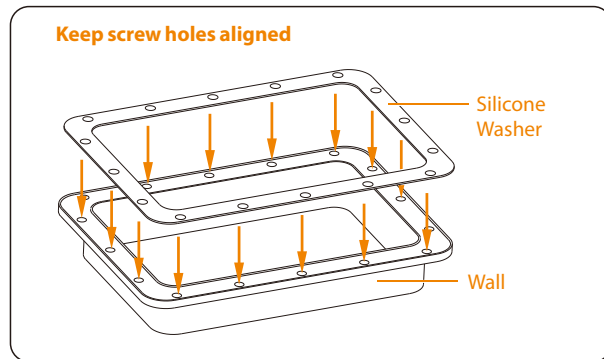

6. After washing, place the resin vat on a workbench, then install the silicone washer.

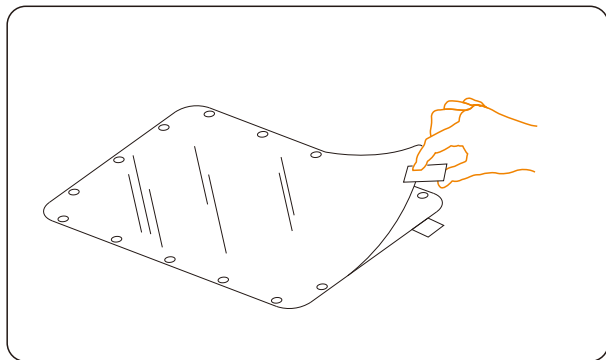

7. Take out a new vat film then tear off the cover.

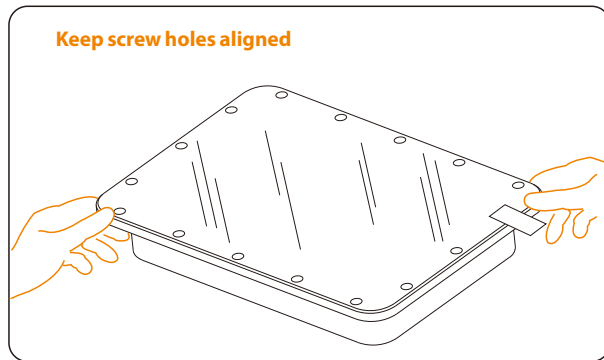

8. Put vat film on the silicone washer, keep screw holes aligned.

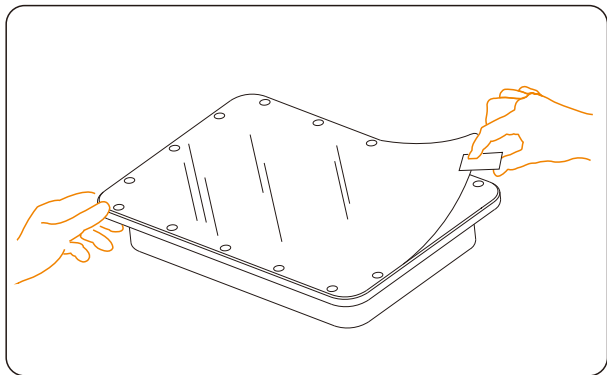

9. Tear off the cover on the other side.

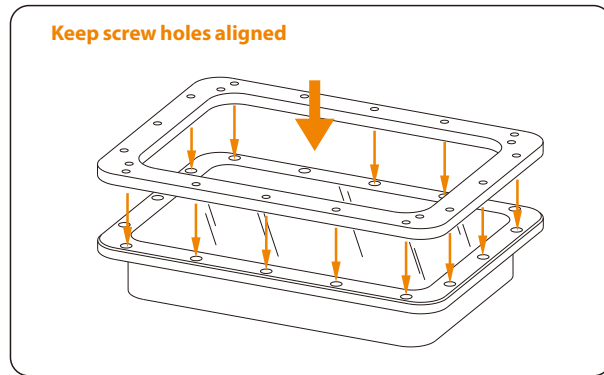

10. Put the film onto the resin vat.

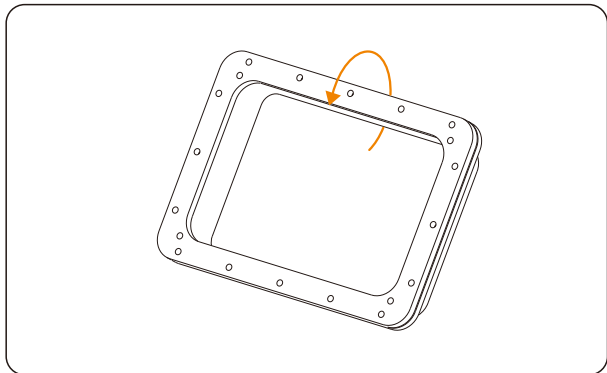

11. Turn over the assembled parts.

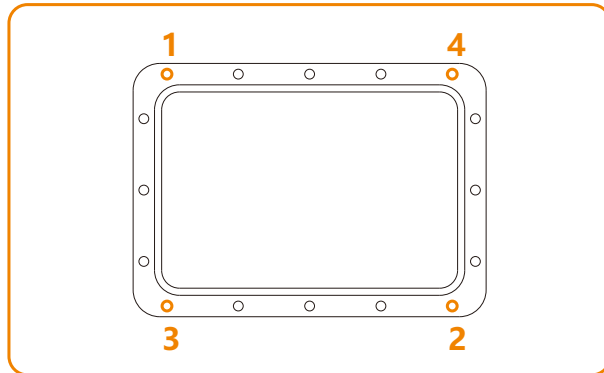

12. Follow the right sequence to install the screws at four corners according to the illustration.

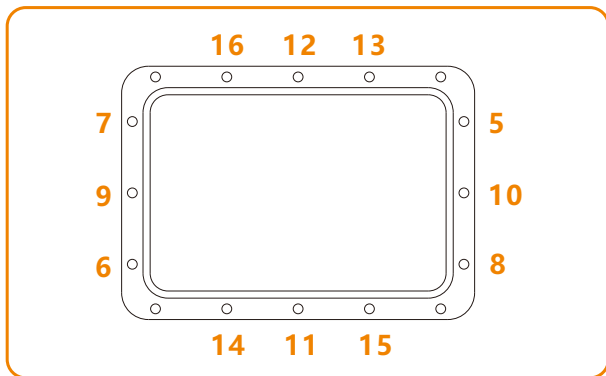

13. Install all the rest screws in the sequence as shown.



14. Put the transparent glass on the vat film

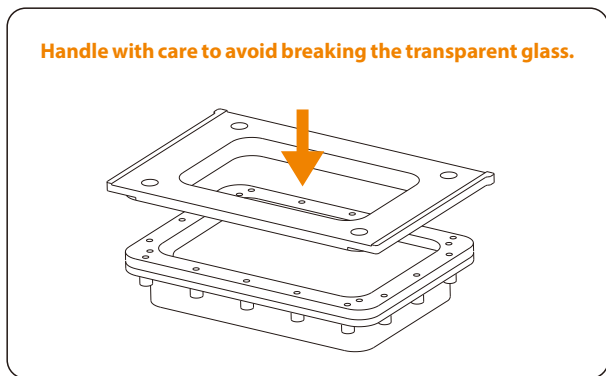

15. Put the bottom plate back into place.

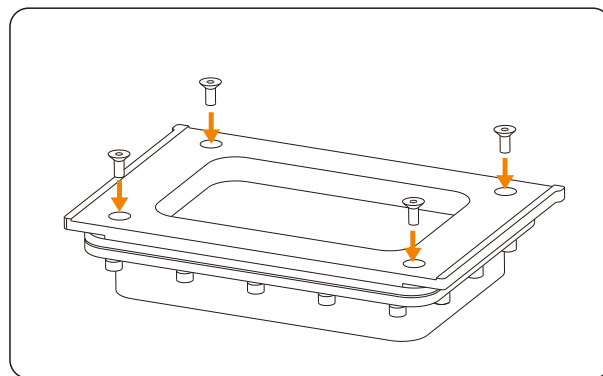

16. Put the four screws half way into the holes and tighten the screws one by one evenly.

10

Basic Maintenance

- Don't pour the used photopolymer resin back to the original bottle!
- Keep the two glass plates (as illustrated) clean and without fingerprint.
- Store the remaining photopolymer resin in a clean sealed container, and keep away from light. Please keep the resin free of any solidified print residue.
- Please dispose the photopolymer resin properly.

